

Assembly, Operating & Maintenance Instructions

buroseating

Remove all items from the carton. Verify all pieces before assembly.

BURO NIMBUS CHAIRS - STANDARD & PLUS MODELS

PART LIST

KEY	QTY	DESCRIPTION
1	2	Armrest
2	1	Seat cushion
3	1	Back cushion
4	12	Screw (5/16" * 2-1/4")
5	1	Allen Key
6	12	Cap

STEP 1.

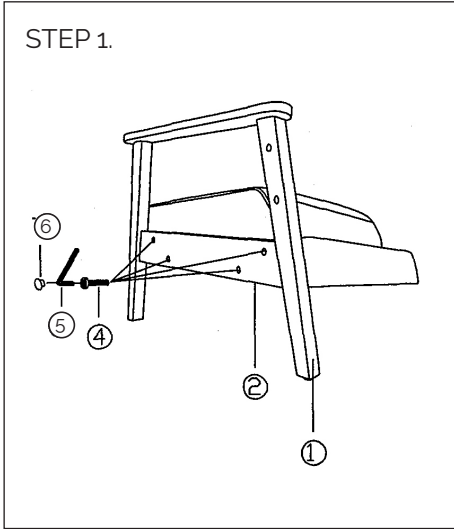

STEP 2.

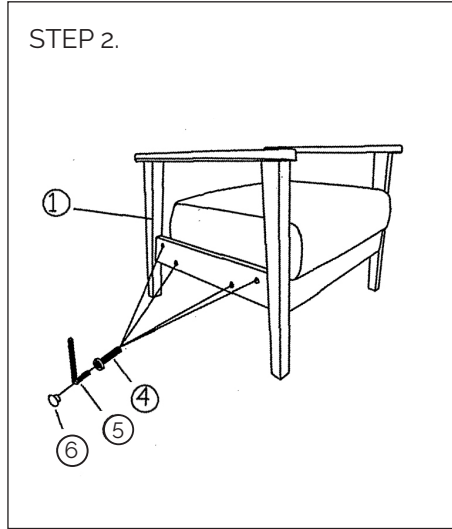

STEP 3.

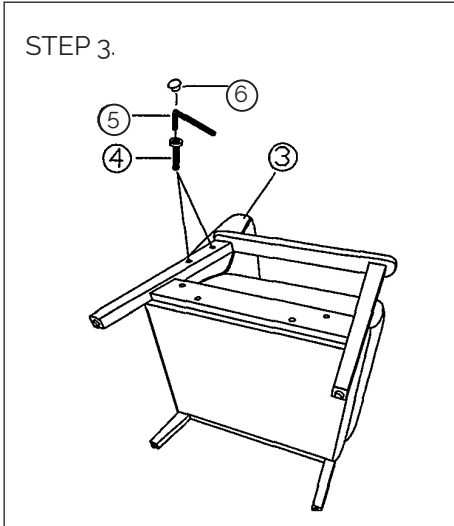

STEP 4.

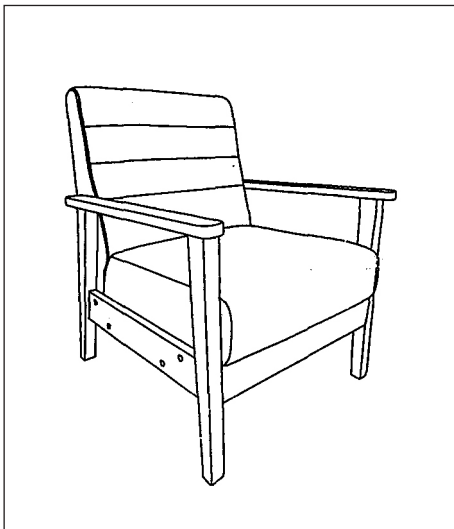
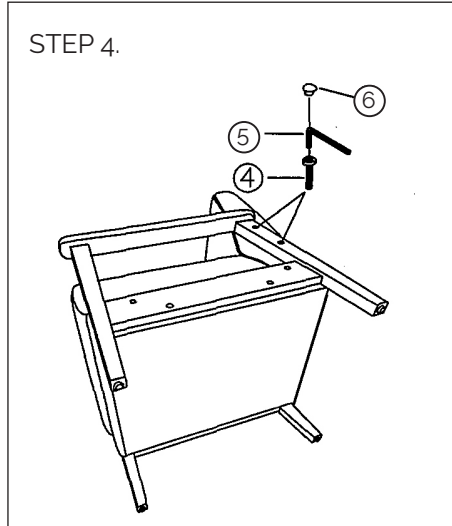

CARE & MAINTENANCE

GENERAL CARE

To maintain the appearance of non-upholstered parts wipe the surface with a clean cloth dampened with a mild detergent solution. Do not remove any parts for separate cleaning. Do not saturate the fabric or interior with water or other cleaning liquids. Do not shampoo clean. Do not clean with hot water extraction machine. Do not clean with onsite drycleaning machine. Protect from direct sunlight, heat and weather.

UPHOLSTERY CARE FOR PU/PVC

Wipe with a clean cloth dampened with a mild upholstery detergent solution • Use only vinyl care products suitable for upholstery vinyl and strictly in accordance with the manufacturer's instructions • Spot clean as above • Treat spills and stains as soon as possible • Persistent stains may require treatment by a professional cleaner • Allow to dry thoroughly before reuse.

UPHOLSTERY & FOAM SPECS*

FOAM

Flame Resistant: Ca117 Section A Part I & Section D Part II

UPHOLSTERY: PU/PVC

Flame Resistance: Ca117 Section E Class I

*This applies only to standard Buro stock. Any customer specified upholstery may not meet these specifications.

PREVENTATIVE MAINTENANCE & WARNING!

- Use this product only for seating one person at a time.
- Do not use this chair as a step stool/ladder.
- Do not sit on any part of the chair except the seat.
- Do not use this chair on uneven floor surfaces.
- Do not interfere with the operating of the gas lift.
- Do not use chair unless all bolts, screws and knobs are tight. At least every six months check all bolts, screws and knobs to ensure they are tight.
- If any parts are missing, broken, damaged or worn do not use the product until repairs are made using factory authorised parts.
- Dispose of packaging properly.
- Plastic bag is not a toy.
- Do not use plastic bag as a head covering as it may cause suffocation.
- Failure to follow these warnings could result in serious injury.